

FULL MOON FULL MOON S

ALT
LÜCIALTERNATIVE

DESIGNER: [Hangar Design Group](#)

HANGING LAMP
WHITE, GREEN OR LEMON PLASTIC DIFFUSER.
CHROME-PLATED METAL.

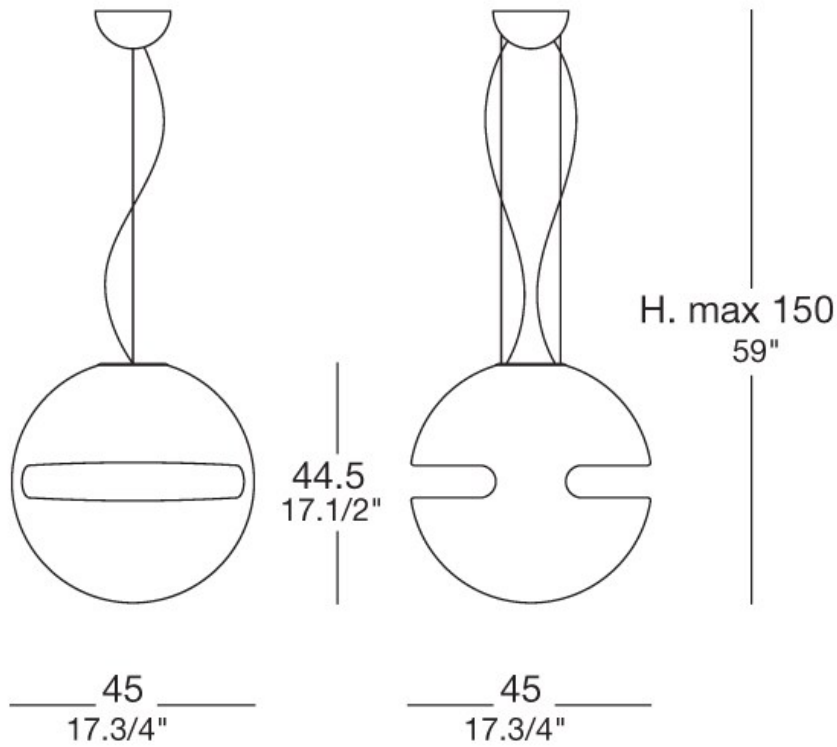

FULL MOON S WEISS Weiß / Verchromt

ARTIKELNUMMER: 0103058013602

GEWICHT (KG): 3

VOLUMEN (M³): 0,125

GLASFARBE: Weiß

GESTELLFARBE: Verchromt

LAMPEN



2 x 100W

oder



2 x 20W

FULL MOON S GRUEN Grün / Verchromt

ARTIKELNUMMER: 0103058014902

GEWICHT (KG): 3

VOLUMEN (M³): 0,125

GLASFARBE: Grün

GESTELLFARBE: Verchromt

LAMPEN



2 x 100W

oder



2 x 20W

ZERTIFIZIERUNGEN



ZERTIFIZIERUNGEN



FULL MOON S GELB
Gelb / Verchromt

ARTIKELNUMMER: 0103058014002

GEWICHT (KG): 3

VOLUMEN (M³): 0,125

GLASFARBE: Gelb

GESTELLFARBE: Verchromt

LAMPEN



2 x 100W

oder



2 x 20W

ZERTIFIZIERUNGEN

